



## Long-Term Freezer

phasetwo's LT series provides farm tanks with the latest technology. When the lid is removed, it is stored in a specific position so the operator can use both hands to quickly access the product in the freezer. With the canister location fixture on the bottom of the unit & numbered location slots on the neck ring, the product location can easily be identified. Our premium multi-layer insulation and other materials, together with the latest vacuum technology systems provides the leading industry performance. Engineering utilized finite element analysis, with specific testing to create durable cryogenic farm tanks suitable for today's requirements.



### FEATURES

- **New one-piece lockable lid design.**
- **Premium materials provide industry leading LN2 performance**
- **Location to store removed Neckplug for faster access to the product.**
- **Ergonomic cast handles.**
- **Numbered canister locations for easy product identification.**



phasetwo®

## GENERAL SPECIFICATIONS

LT - Series Model	LT10	LT21
LN2 Capacity (L)	10	21.6
Outer Diameter (in/mm)	11.4 (290)	14.5 (368)
Overall Height (in/mm)	23.8 (603)	25.9 (658)
Neck Opening (in/mm)	2.19 (56)	2.19 (55.6)
Weight Empty (lbs/kg)	16 (7.3)	26.2 (11.9)
Weight Full (lbs/kg)	33.8 (15.3)	63.4 (28.8)
Canister Dimensions (ins/mm)	1.65x11 (42x279)	1.65x11 (42x279)
Static Days	105	227
Normal Evaporation Rate (L/day)	.095	.095
1.2 & 2ml Vial (6/cane)	210	210
1/2cc Straws (10/cane)	720	720

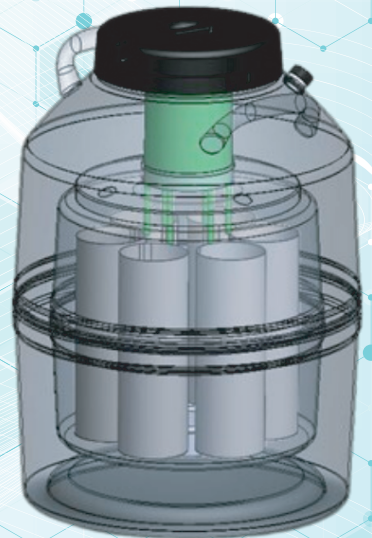

**Materials and Workmanship: 2 year warranty**  
**Vacuum: 5 year warranty**